



# Spout inserting machine

## SI-60 (\*)



### Description:

**SI-60** is a servo driven, fully automatic spout inserting machine fitted for larger production plants. This thermal spout inserting machine is an industrial spout sealing machine for companies who need a machine with high production capacity.

The SI-60 is a high capacity spout inserting machine, set up to handle up to 60 spouts per minute.

This SI-60 spout inserter is made for sealing the spout to the pouch at high speeds with high accuracy. By fixing the pouch and spout in the machine, we avoid having spouts that are not well centered and aligned.





Any change, whether it be format, spout size or moving the position of the spout from the center to the corner spout, is done in minutes rather than hours. This machine decimates the time it use to take to make changes.

Not only do we build this machine on an advanced technological platform, but it is also possible to accommodate additional options or personalization according to your specific needs and wishes.

### Possible spout positions and pouch shapes:

- Center, off center and corner spout insertor. Special shapes of pouches are possible but can be subject to technical assessment.
- Pouch shape – square, round or shaped. In some cases special tooling for handling certain shapes will be needed.





## Machine Specifications for this machine model SI-60



Pouch Dimensions (min – max)	
Width	65 – 320 mm
Length	90 – 400 mm

Description	Specifications
Type of pouches	Pre-made standing pouch, side seal pouch, bag of co-ex material or laminate material with inside PE or PP sealant layer. 100% mono material – PE or PP
Number of Feeding Stations	1
Number of Sealing Stations	Up to 4
Spout Position	Top Center, Corner & off center
Pouch loading system	Automatic
Spout inserting process	Automatic
Voltage	3 x 380 V + N + PE
Frequency	50 - 60 Hz
Current Load	5 A
Power Line	60 A
Compressed Air	150 Lpm, 6 bar
Pouch range	25 ml – 6.000 ml
Pouches per minute	Up to 60 ppm



Dimensions	
Machine weight	+/- 2.800 kg
Surface space needed	4,50 m x 4,50 m
Height needed	2,50 m



## Machine Compliance:

- Machinery Directive 2006/42/EG
- Machine complies with EU, UL and CSA Standards upon request.
- CE marked



## Features

- Heavy duty construction.
- High Performance – machine can be equipped with a vision control camera system (mono or dual) that will control tolerance spout/pouch position.
- Flexible machine that can insert top and corner spout for a wide range of pouch sizes (width 65 – 320 mm and length – 90 – 400 mm) and film thickness from 80 to 1.200 µm
- Machine will be fed with pre-made standing pouch, three side seal pouch and side gusset pouch.
- Sealing stations can be easily removed into a position for cleaning or maintenance purposes
- Safe to operate machine.

## Options

- Feeding on rail system instead of using the out feed conveyor belt the pouches will be fed directly onto a plastic rail. We can also outfeed pouches flat onto a feeding rail.
- Remote technical support possible.
- Universal spout insertor sorting bowl to handle many different types of spouts on the same feeding system

## Advantages

- Very quick change over from one spout to another (less than 10 minutes)
- Only a small space is needed to run many different types of spouts.
- Consisting of:
  - Sorting bowl
  - Feeding selection linear system
  - Small Elevator for rejection parts
  - Pick and place system
  - One set of sealing tools for one spout size

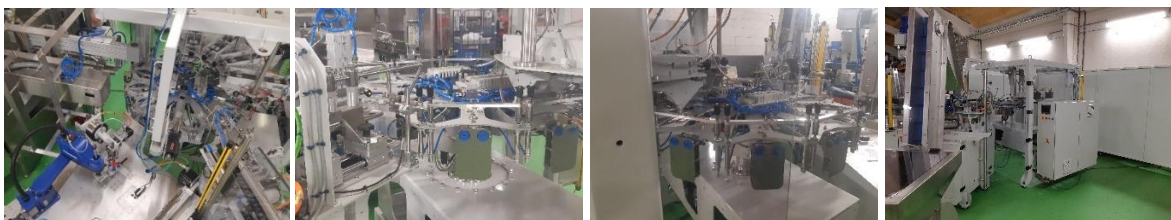





### Machine Layout:



scaldopack  
WE HANDLE YOUR POUCH  
WWW.SCALDOPACK.BE

Machine weight	2800 kg
Voltage	3x-380V + N + PE
Frequency	50-60Hz
Current Load	5 A
Power Line	50 A
Compressed Air	150 l/min, 6 bar
Pouches per minute	-/7-60

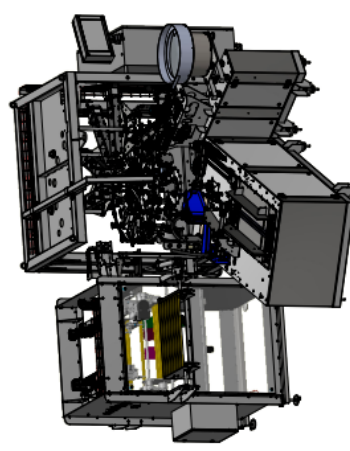

- 1: Loading station
- 2: PreOpening
- 3: Spout place unit
- 4: Sealing station1
- 5: Sealing Station2
- 6: Sealing Station3 (optional)
- 7: Sealing Station4 (optional)
- 8: Sealing Station5 (optional)
- 9: Cooling station
- 10: Reject Station and Camera Station (Optional)
- 11: Outfeed + buffer
- 12: Free

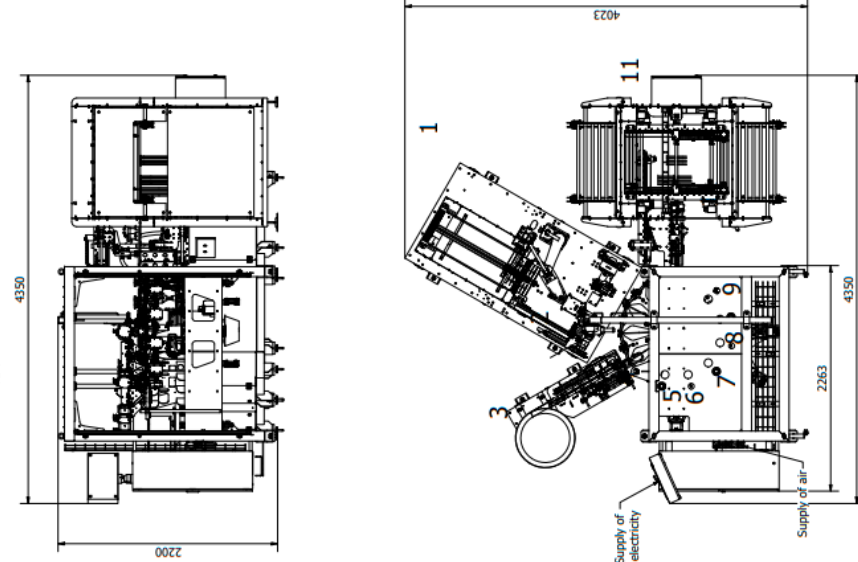
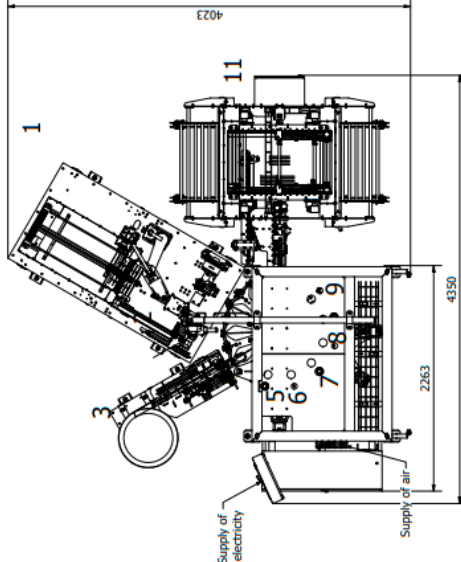
Index	DESCRIPTION	Date	Name
REVISION HISTORY			
	Material: RQ		Visible faces:
	Designer: RQ		used faces:
	Checked: RQ		remarks:
	Date: 29/09/2020		Sheet size: A2
	Projection: 4		Part nr.: 90-A039-BAKE
			Description: S140 file

(\* ) All information and measurements mentioned in this document are merely indicational and for informational purposes only. Information and measurements in this document can be subject to changes without further notice. For the latest info always revert to Scaldopack.